

Modelling and Simulation of the Electrothermal Gas Micro-Flowmeter Static Behaviour

R.C. Moldovan, D. Perju, M. Suta, M. Calisevici, S. Marinescu

Politehnica University of Timișoara, Faculty of Industrial Chemistry and Environmental Engineering,
Piața Victoriei 2, 300006, Timișoara, Romania, E-mail: raul.moldovan@chim.upt.ro

Abstract: The complex problem of small gas flow measuring in chemical industry pilot plants represents a constant field of research. So, the electrothermal gas micro-flowmeter realized in the Chemical Processes Automation Laboratory of the Industrial Chemistry and Environmental Engineering Faculty of Timișoara, fits the laboratory apparatus requirements. The studied flowmeter can be used with high accuracy as measuring transducer for automatic adjustments of small gas flows. The mathematical correlation of the main constructive and functional parameters of the apparatus allowed obtaining of mathematical models for the assessment of certain predictions of the flowmeter behaviour. The simulation of the static behaviour of the electrothermal gas micro-flowmeter has proven to be a functional simulation and the operation equation can be considered a valid model due to the fact that its manipulation is a real and correct representation of the real system operation.

Keywords: flowmeter, flow measurement, mathematical modeling, simulation, static behaviour.

1. Introduction

Measuring low and very low gas flows is a problem encountered very often, especially in research installations from different fields.

In the chemical industry, characterised by complex technological processes, which are distinguished by the rapid development and by a high sensitivity to any alteration of the established regime, by noxiousness, fire or explosion danger, the flow – together with the pressure, temperature and level – is a parameter, which never misses from a process automatic adjustment system [1]. In this particular case, there is the need to use other solutions than the classical ones, taking into consideration also the work environment: high pressure conditions, toxic environment, etc. Using thermal flowmeters is one way. Therefore, the technical, metrological, economical and safety performances for this type of flowmeters need to be improved [2].

The electrothermal micro-flowmeter, part of the thermal flowmeters class, allows the indirect determination of the mass flow rate by measuring the temperature differences which appear due to the thermal transfer, between a heat source and the gas carried away with a certain velocity.

The mathematical models are useful in the research activity, for the process simulation in different situations, designing, deciding the structure complexity of the automatic control system, optimal controller parameter selection and establishing an optimal control method, adaptive or multivariable.

The modelling and simulation is a complex of associated activities involved in the creation of real systems models and their simulation by means of the electronic computer. The advantages of the simulation consist in allowing experiences on a model that is a symbolic

representation of the system [3]. The system model is the mathematic representation of the dependence between various proportions (input, output, intermediary), dependence that corresponds to a feasible physical process [4]. The quality of a model is expressed, first, in the accuracy of models to reproduce the known behaviour of the modeled system. The behaviour of the model is material by operation, therefore, within the operations connected to modelling, which belong to simulation [5].

A new tendency in approaching the modeling theory consists of reconsidering the role of the means, which support the modeling activities. Thus, Z.P. Zeigler's approach can be noticed; he built up the modeling theory as a coherent structure made of five basic elements, which are inter-connected by the so-called specific modeling relations (validation, simplification, simulation). This structure integrates the electronic computer, which is compulsory for the operation of the modeling processes [5].

The basic elements of the modeling theory are defined by the systems theory concepts and consist of [5]: the real system, the basic model, the experimental environment, the lumped model and the computer.

The purpose of this work is to study the behaviour of the electrothermal gas micro-flowmeter, designed and manufactured in the Chemical Processes Automation Laboratory of the Industrial Chemistry and Environmental Engineering Faculty of Timișoara, to obtain dependency equations between the parameters which characterize its operation and simulate the static behaviour based on the operation equation cited by specialised literature.

2. Experimental

The operation principle of the electrothermal gas micro-flowmeter is illustrated in Fig. 1 [6, 7].

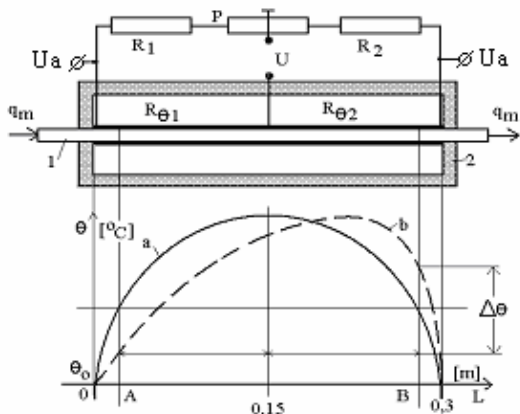

Figure 1. Operation principle of the electrothermal gas micro-flow meter

The gas flow is passing through a thin walls metal tube 1 that controls the heat. On the tube there are, isolated and symmetrical, two windings (on one side, as thermally sensitive resistance elements $R_{\theta 1}$ and $R_{\theta 2}$ connected in a bridge circuit; on the other side, as heating source). When the tube is flow less, the temperature is distributed symmetrically, the maximum being in the middle (graph "a" from Fig. 1). This distribution is deformed under the influence of the gas flow. Therefore, in two symmetrical points A and B compared to the middle of the tube (graph "b"), there is a temperature difference $\Delta\theta$.

The entire tube is introduced in thick walls protective cover 2 made of a material with a high thermal conductivity. The purpose of the protective cover is to balance the temperature on the two heads and to reduce the influence of the environment parameters (local temperature fluctuations) on the flowmetric tube.

Equation (1) represents the electrothermal micro-flowmeter operation equation [7, 8]. The equation (1) corroborated with the equation (2) represents the basic model, which represents the image by means of which is perceived the real system. It's a model able to hypothetically reproduce, if necessary, the entire behaviour of the system. The basic model is fully valid if it reproduces with high accuracy the behaviour of the real system in all experimental environments [5].

$$U = K \cdot qm \tag{1}$$

$$K = B \cdot Cp \tag{2}$$

Where: U – disequilibrium voltage of the Wheatstone bridge, [V];

qm – gas mass flow rate, [kg·s⁻¹];

K – apparatus sensitivity, [V·s·kg⁻¹];

B – constant that depends only on the constructive and functional parameters, [V·s·°C·J⁻¹] [9];

Cp – specific heat, [J·(kg·grd)⁻¹].

Consequently, the disequilibrium voltage U is proportional to the gas weight rate qm and to its specific heat Cp .

3. Results and discussions

The experimental determinations were made by measuring for various values of the air mass flow rate qm the disequilibrium voltage U , at various heating powers P .

In table 1 are presented the main parameters, which characterise the static behaviour of the electrothermal micro-flowmeter and the apparatus sensitivity K defined as the ratio between ΔU and Δqm . These parameters represent the experimental environment, defined, as the limited circumstances set were the real system should be observed and understood in order to accomplish the modeling [5].

TABLE 1. Main parameters that define the static behaviour of the electrothermal gas micro-flowmeter

Case	P [W]	qm·10 ³ [kg/s] Range	U·10 ³ [V] Range	K [V·s/kg]
1.	0.85	0.20 – 1.02	1.70 – 9.10	9.024
2.	1.26	0.27 – 1.05	3.90 – 15.1	14.359
3.	1.495	0.10 – 1.09	1.90 – 19.3	17.665
4.	1.71	0.30 – 1.17	5.95 – 24.4	21.086
5.	2.30	0.17 – 0.69	5.20 – 21.4	31.456

The mathematical model of a process is represented by the relationship between the process outlet value and the inlet values [10]. In our case, the mass flow rate qm represents the micro-flowmeter inlet value and the disequilibrium voltage U represents the outlet value. Thus, we have deduced the equation (3), which represents the general form of the equation that describes the static behaviour of the electrothermal micro-flowmeter.

$$U = a + b \cdot qm \tag{3}$$

In table 2 are presented the coefficients of equation (3), calculated by the smallest squares method [11,12], and the accuracy indicators of the generated mathematical models (correlation coefficient R and standard deviation SD). The coefficients of the equations that describe the operation of the electrothermal micro-flowmeter and the accuracy indicators were calculated using the Matlab programme [12,13].

TABLE 2. Equation (3) coefficients and the accuracy indicators

Case	Equation's coefficients		Accuracy indicators	
	a	b	R	SD
1.	-8.60·10 ⁻⁵	9.00	0.99	0.26·10 ⁻⁴
2.	1.28·10 ⁻⁵	14.38	0.99	0.31·10 ⁻⁴
3.	6.39·10 ⁻⁵	17.71	0.99	0.49·10 ⁻⁴
4.	-25.69·10 ⁻⁵	21.08	0.99	0.39·10 ⁻⁴
5.	-22.07·10 ⁻⁵	31.62	0.99	0.72·10 ⁻⁴

In Figure 2 are presented the static characteristics of the electrothermal gas micro-flowmeter for five heating powers (0.85 W, 1.26 W, 1.495 W, 1.71 W, 2.3 W).

It can be noticed that these characteristics are lineal and together with the increase of the heating power it also

increases the disequilibrium voltage of the electrothermal micro-flowmeter, thus the apparatus sensitivity.

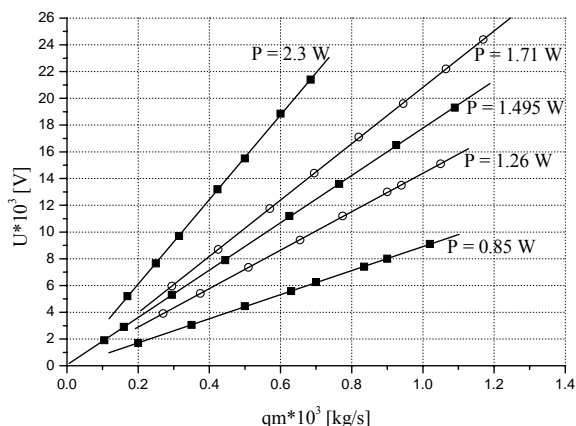

Figure 2. The static behaviour of the electrothermal gas micro-flowmeter

In Figure 3 is presented the interdependence between the apparatus sensitivity K and the heating power P, dependency, which is lineal within the limits of the studied domain. This dependence is described by equation (4), for which were calculated the correlation coefficient R=0.997 and the standard deviation SD=0.768.

$$K = -4.935 + 15.531 \cdot P \quad (4)$$

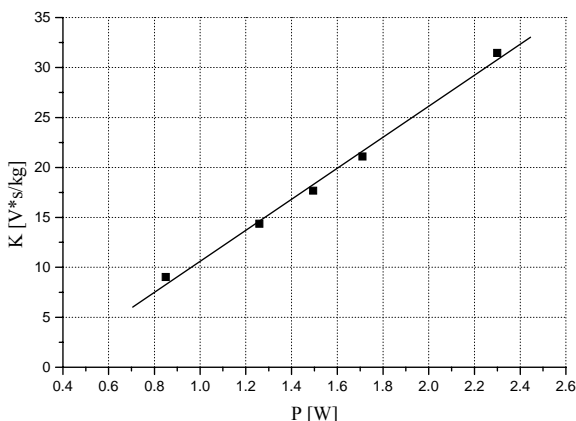

Figure 3. The interdependence between the apparatus sensitivity K and the heating power P

In many practical cases, the connection between two or more parameters that describe a certain process is tight enough so that the variation of a parameter can be controlled and expressed based on the variation of the other parameters. These sort of functional connections are called stochastic or probabilistic connections. The study of this type of connections has led to the development of the multiple correlation theory [14].

Within this study was evaluated the effect that two factors influence might have by making an analysis of the multiple correlation between the disequilibrium voltage U, as dependent variable, respectively the gas mass flow rate qm that is carried away through the flowmeter tube and the

heating power P, the latest two being independent variables. For an accurate description of the dependence of the disequilibrium voltage of the gas mass flow rate upon the filament power, the lineal multiple correlation and second-degree polynomial correlation were obtained, analysed and compared. Equation (5) and (6) represent the general form of the mathematical models and in table 3 are presented the equations coefficients and the models accuracy indicators.

$$U = a_0 + a_1 \cdot P + a_2 \cdot qm \quad (5)$$

$$U = a_0 + a_1 \cdot P + a_2 \cdot qm + a_3 \cdot P^2 + a_4 \cdot P \cdot qm + a_5 \cdot qm^2 \quad (6)$$

The following models accuracy indicators have been calculated: dispersion σ^2 (7), model accuracy indicator R^2 (8) and correlation coefficient R (9) [12].

$$\sigma^2 = \frac{\sum_{i=1}^n (\hat{y}_i - y_{i\text{calc}})^2}{n - m - 1} \quad (7)$$

$$R^2 = \frac{\sum_{i=1}^n (y_{i\text{calc}} - \bar{y})^2}{\sum_{i=1}^n (\hat{y}_i - \bar{y})^2} \quad (8)$$

$$R = \sqrt{1 - \frac{\sum_{i=1}^m (\hat{y}_i - y_{i\text{calc}})^2}{\sum_{i=1}^n (\hat{y}_i - \bar{y})^2}} \quad (9)$$

Where: \hat{y}_i – experimental value; y_i – value resulted for y on the basis of the regression equations; \bar{y} – experimental values average; m – independent variable; n – number of data sets.

TABLE 3. The mathematical models coefficients and the models accuracy indicators

Equation's Coefficients	Equation (5)	Equation (6)	
	a_0	-0.012	0.002
a_1	0.008	-0.003	
a_2	17.662	-3.338	
a_3	-	0.001	
a_4	-	14.807	
a_5	-	-642.508	
Accuracy indicators	R	0.991	0.999
	R^2	1	1
	σ^2	$2.92 \cdot 10^{-6}$	$0.03 \cdot 10^{-6}$

The obtained experimental data were processed by Statistica 6.0 program, obtaining a surface (Fig. 4) whose behaviour is given by equation (6). Equation (6) describes with a higher accuracy the behaviour of the electrothermal micro-flowmeter in study, within the operating conditions stipulated in table 1. The accuracy indicators of the models confirm this. The correlations presented in Fig. 5 and Fig. 6 also highlight the accuracy of the mathematical models

generated by disposing almost symmetrically (for equation (5)), respectively symmetrically (for equation (6)), the experimental results with those obtained based on the mathematical model.

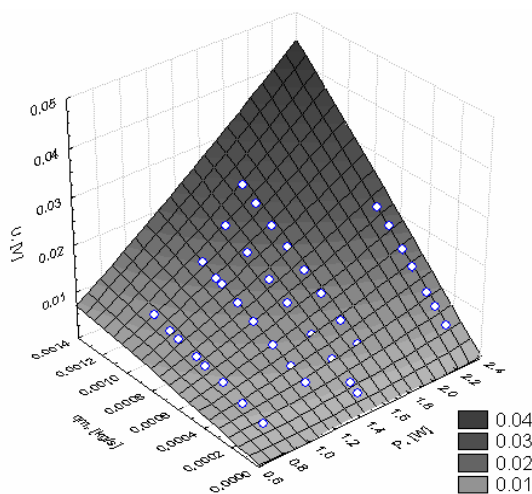

Figure 4. Dependence of the disequilibrium voltage U on the gas flow rate q_m and heating power P

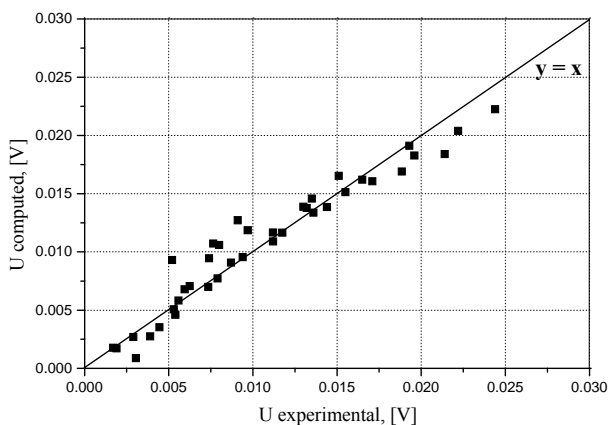

Figure 5. Correlation between the experimental results and the results obtained based on the mathematical model – for equation (5)

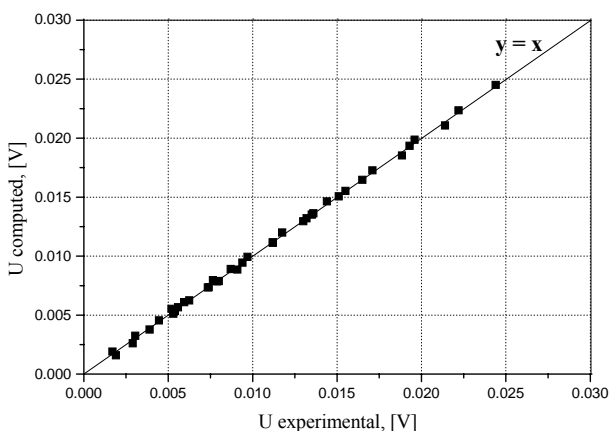

Figure 6. Correlation between the experimental results and the results obtained based on the mathematical model – for equation (6)

The lumped model is the closest concept to the basic model. This represents the system able to reproduce the real system behaviour at the outlet by means of the limitations imposed within the experimental environment [5]. Thus, we can state that the equations (3), (5) and (6) represent lumped models that describe the static behaviour of the electrothermal micro-flowmeter in study. There can be various valid lumped models and each of them can be valid only within a determined experimental environment and not in others.

Simplifying the basic model, in accordance with the modeling theory [5], we can consider equation (1) a lumped model, the purpose of simplification being to find the most efficient model whose behaviour is close to the real behaviour of the system. Thus, the simulation process with lumped model can be considered a checking of the system behaviour.

Next we have simulated the static behaviour based on equation (1), taking into consideration the data obtained within the experimental environment.

For simulation were chosen five sets of experimental data obtained by measurement for various air mass flow rates, ranging between $0.1 \cdot 10^{-3}$ – $1.22 \cdot 10^{-3}$ kg/s, the disequilibrium voltages at various heating powers (1.15 W, 1.85 W, 2 W, 2.15 W, 2.5 W).

For a better accuracy of the static behaviour simulation by means of equation (1) was considered necessary the adjustment of sensitivity K by replacement with K' . This represents the product between K and a correlation factor determined by simulation in the Matlab programming environment for the cases presented in table 1. The values of the adjustment factors are close to each other, their arithmetical mean being 0.9942.

Thus, equation (1) becomes equation (10):

$$U = K' \cdot q_m \quad (10)$$

The K' value necessary to simulation can also be determined by using equation (11) – deduced from the domains of the experimental environment presented in table I.

$$K' = -4.719 + 15.31 \cdot P \quad (11)$$

In Fig. 7 is presented the static behaviour of the electrothermal micro-flowmeter obtained by simulation in the Matlab programming environment. The result of the simulation can be described by an equation looking in general as the equation (3), the coefficients of the equation for the five simulated cases being presented in table 4.

One of the tasks of our study is to make appreciations on the validity of the simulated model. This means the corroboration of the results obtained by simulation with the data obtained from the source-system. It can be noticed a good correlation between the simulation result and the experimental data, correlation also confirmed by the accuracy indicators presented in table 5.

The simulation must reproduce accurately the conditions in which the source for acquisition was

operated, and identify exactly the source of the obtained data evolution (evolution due to changes in parameters area, structure, etc.) [5].

A potential definition of the validation concept takes into account the way that the model adjusts to real conditions, thus, the way in which predictions meet observations [5].

Many of the techniques used to validate the models are also used to check the simulations. To validate the simulations were calculated the following accuracy indicators [12]: accuracy dispersion σ^2 (7), model accuracy indicator R^2 (8) and the correlation multiple coefficient R (9).

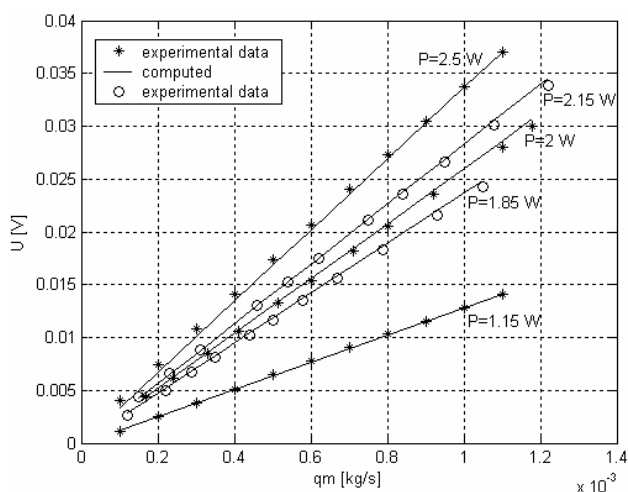

Figure 7. The simulation of static behaviour of the electrothermal micro-flowmeter

TABLE 4. The coefficients of the equation that describe the simulation

Case	P [W]	Equation's coefficients	
		a	b
1 st Simulation	1.15	$1.09 \cdot 10^{-5}$	12.85
2 nd Simulation	1.85	$0.73 \cdot 10^{-5}$	23.65
3 rd Simulation	2.00	$0.17 \cdot 10^{-5}$	26.00
4 th Simulation	2.15	$-0.18 \cdot 10^{-5}$	28.29
5 th Simulation	2.50	$-1.27 \cdot 10^{-5}$	33.72

TABLE 5. The accuracy indicators for the simulated cases

Case	σ^2	R^2	R
1 st Simulation	$0.80 \cdot 10^{-8}$	1.00	0.99
2 nd Simulation	$11.9 \cdot 10^{-8}$	1.00	0.99
3 rd Simulation	$9.90 \cdot 10^{-8}$	1.00	0.99
4 th Simulation	$4.80 \cdot 10^{-8}$	1.00	0.99
5 th Simulation	$27.5 \cdot 10^{-8}$	0.98	0.99

Based on the calculation of the accuracy indicators it can be noticed the maximum value of the accuracy indicator R^2 for the first four simulated cases, the heating power used for determination within the experimental environment presented in table 1. The simulation no. 5 is made at a higher power, but in this case also, we can state that the simulation reproduces the evolution of the experimental data.

4. Conclusions

The electrothermal micro-flowmeter studied allows the measurement in basic apparatus-like conditions of small gas mass flow rates, the interval studied ranging between $0.1 \cdot 10^{-3} - 1.3 \cdot 10^{-3}$ kg/s air, a flow domain which interferes quite frequently with the research apparatus in the chemical industry. As long as there is a lineal dependence between the disequilibrium voltage and the gas mass flow rate and the apparatus was calibrated for a gas with a certain specific heat, the flowmeter can also measure the mass flow rate of other gases just by applying the necessary adjustment.

Moreover, the electrothermal micro-flowmeter can be used as sensitive element in the automatic adjustment loops for small gas mass flow rates. Generating as outlet signal an analogical electrical value, it can be easily connected as sensitive element to the conventional steering devices or by means of interface equipment to the process computers.

The apparatus presents a good sensitivity and a lineal dependence between the mass flow rate and voltage, the correlation coefficient being a very good one ($R=0.99$). The apparatus sensitivity, in accordance with our expectations, increases together with the heating power.

By using the multiple correlation method, it was highlighted the dependence existing between the disequilibrium voltage and the operational parameters: the gas flow, which is carried away through the flowmeter tube and the heating power. The correlative analysis between these parameters, by the calculated accuracy indicators, highlights the accuracy of the generated mathematical models. The mathematical models can be considered valid only if they are faithful to the real system by means of the experimental environment for which it was defined. Thus, the equations of the mathematical models can approximate the variation of the disequilibrium voltage within the operating domains stipulated in table 1. This is both a control and prediction regarding the appreciation of apparatus performances. The models predictions can also represent a criterion in establishing the optimum operation and exploitation conditions.

The simulation of the static behaviour of the electrothermal micro-flowmeter has proven to be a functional simulation and the operation equation can be considered a valid model due to the fact that its manipulation is a real and correct representation of the real system operation.

In order to obtain results to describe as accurate as possible the real behaviour of the electrothermal micro-flowmeter, by simulation with equation (1), it is compulsory to apply an adjustment factor. In this case also we have to take into account the exploited experimental environment.

REFERENCES

- Perju D., Ţuta M., Rusnac C., Brusturean G.A., Automatizarea proceselor chimice. Aplicații 1, Editura Politehnica, Timișoara, 2005.
- Perju D., Ţuta M., Pîrlea H., Moldovan R.C., Possibilities for Constructing and Using an Electrothermal Gas Micro-Flowmeter with

- Digital Displaying, *Microcad 2005 International Scientific Conference, Miskolc, Hungary*, **2005**, p. 101-106.
3. Pocinog G., *Modele și metode de simulare*, Editura Eurobit, Timișoara, **1998**.
 4. Dulău M., Oltean S., *Modelare și simulare*, Universitatea Petru Maior, Târgu Mureș, **2003**.
 5. Savii G., Luchin M., *Modelare și simulare*, Editura Eurostampa, Timișoara, **2000**.
 6. Perju D., Todinca T., *Automatizarea proceselor chimice, Centrul de multiplicare Universitatea Tehică Timișoara*, **1995**.
 7. Perju D., Todinca T., Șuta M., Rusnac C., *Echipamente de automatizare pneumatice de joasă presiune. Aplicații*, Editura Politehnica, Timișoara, **2001**.
 8. Perju D., Șuta M., Rusnac C., *Echipamente de automatizare pneumatice de joasă presiune*, Editura Politehnica, Timișoara, **2003**.
 9. Perju D., Deaky A., Todinca T., *Influența parametrilor funcționali asupra performanțelor microdebitmetrului pentru gaze*, *Buletinul științific și tehnic al Institutului Politehnic „Traian Vuia” Timișoara, seria Chimie*, Tom 25 (39), Fascicola 1, **1980**.
 10. Agachi Ș., *Automatizarea proceselor chimice*, Casa Cărții de Știință, Cluj Napoca, **1994**.
 11. Lungu A., *Modelări numerice în hidrodinamică*, Editura Tehnică, București, **2000**.
 12. Todinca T., Geantă M., *Modelarea și simularea proceselor chimice. Aplicații în Matlab*, Editura Politehnica, Timișoara, **1999**.
 13. Ghinea M., Fireșteanu V., *Matlab. Calcul numeric. Grafică. Aplicații*, Editura Teora, București, **2001**.
 14. Constantin Gh., Negrea R., *Lecții de statistică descriptivă*, Universitatea de Vest Timișoara, **2004**.